

4942

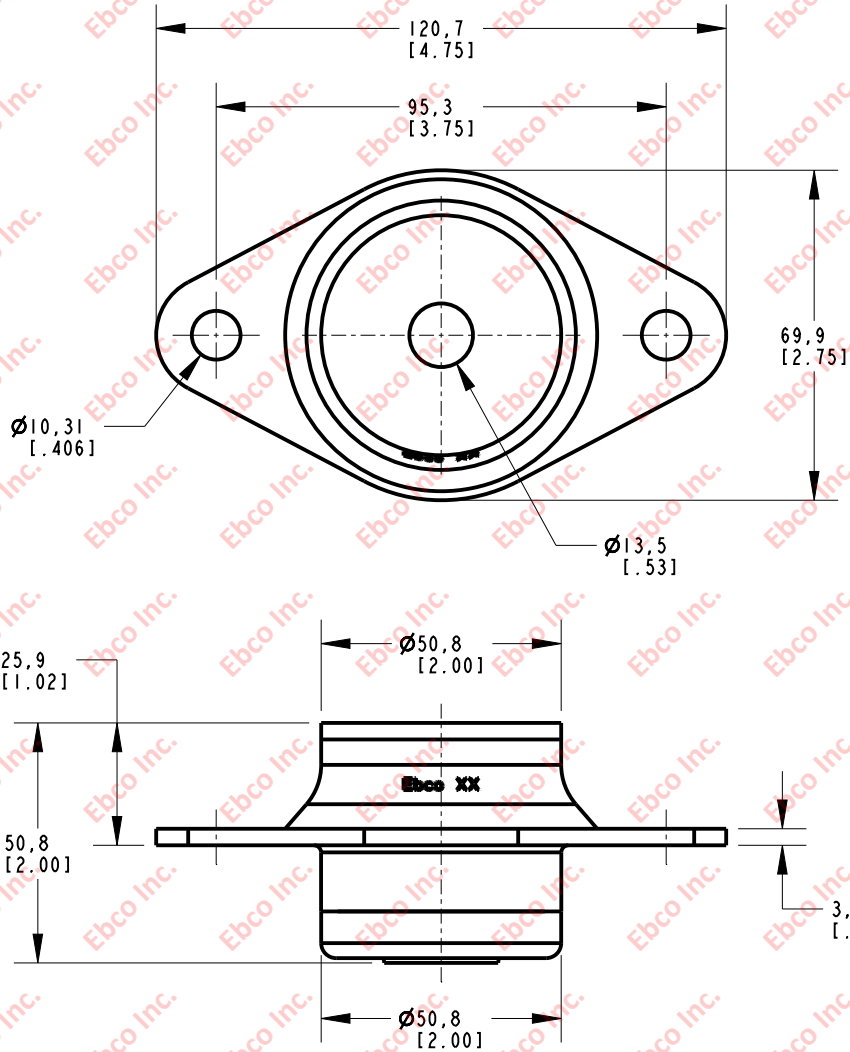

INSTALLATION VIEW (Shown under no load)

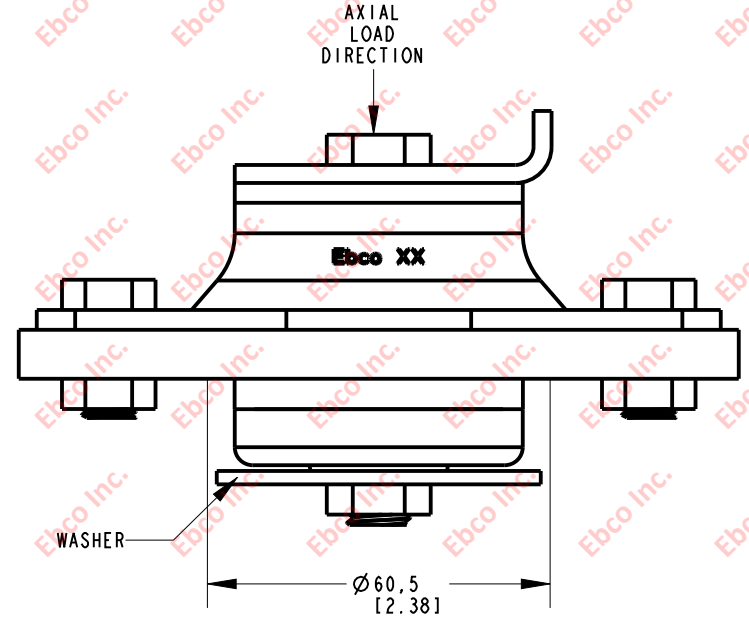

INSTALLATION DIMENSIONS

RECOMMENDED BOLT INFORMATION				TIGHTENING TORQUE			
ENGLISH		METRIC		CLAMP LOAD		TIGHTENING TORQUE	
SIZE	GRADE	SIZE	CLASS	lb	N	ft-lb	N-m
1/2	5	M12	9.8	9046	40239	75.4	101.8
WASHER SPECIFICATIONS							
O. D.		I. D.		THICKNESS			
in	mm	in	mm	in	mm		
2.25	57.15	.51	12.95	.125	3.18		

SPECIFICATIONS

PART NUMBER		MAX. AXIAL DEFLECTION		MAX. AXIAL LOAD	
NATURAL RUBBER	NEOPRENE	in	mm	lb	N
4942-72	4942-82	.15	3.81	325	1446
4942-73	4942-83			400	1779
4942-74	4942-84			500	2224
4942-75	4942-85			600	2669



TITLE:	4942		
THE INFORMATION CONTAINED IN THIS DRAWING IS THE SOLE PROPERTY OF EBSCO ANY REPRODUCTION IN PART OR AS A WHOLE WITHOUT THE WRITTEN PERMISSION OF EBSCO IS PROHIBITED.			
TOLERANCES PER RMA STANDARD	REV.	DATE:	UNITS:
A3	B	03-31-23	mm [INCH]
1330 HOLMES RD. ELGIN, IL 60123			

SPECIFICATIONS SUBJECT TO CHANGE