

4641

IMP. NO.

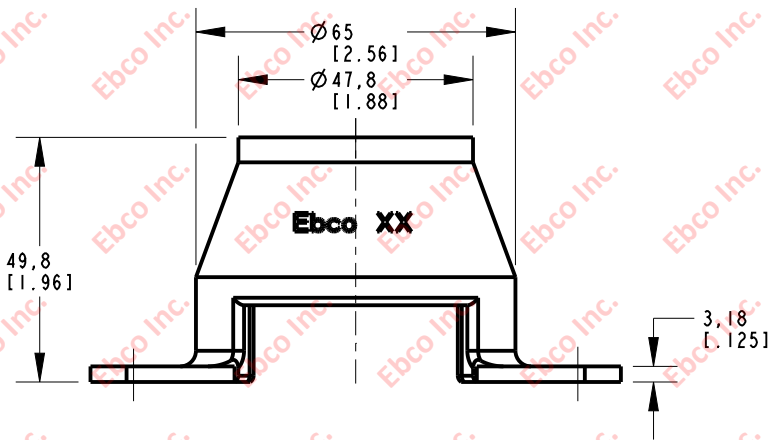

INSTALLATION VIEW (Shown under no load)

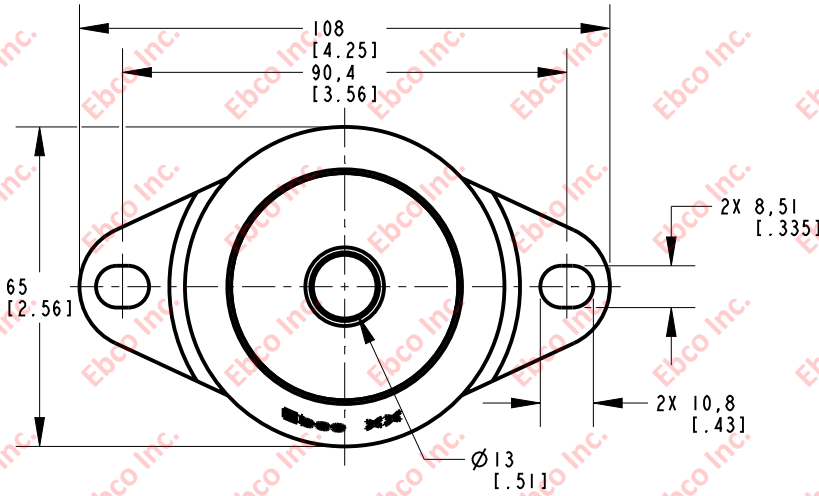
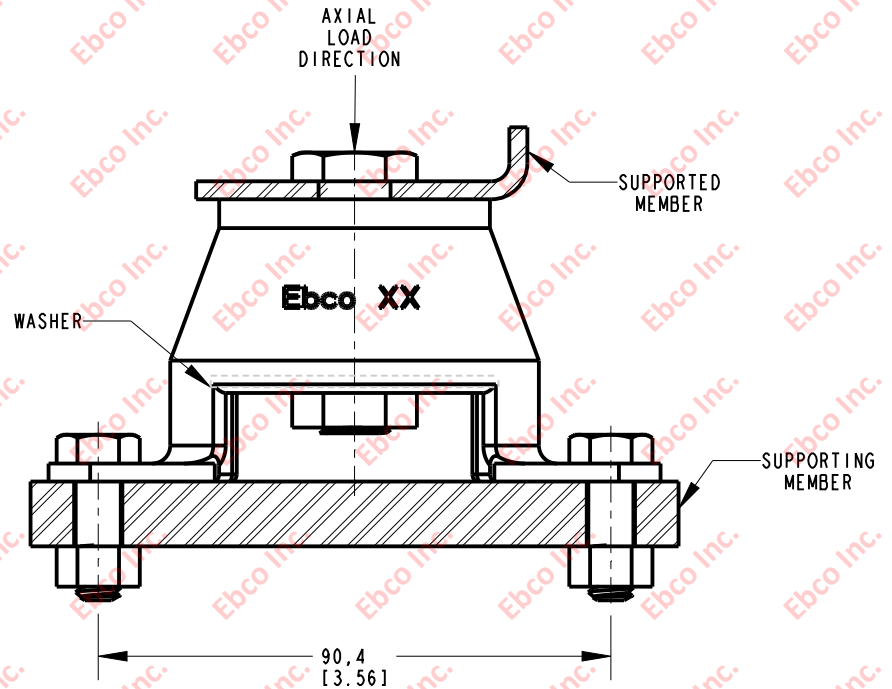

SPECIFICATIONS

RECOMMENDED BOLT INFORMATION				TIGHTENING TORQUE			
ENGLISH		METRIC		CLAMP LOAD		TIGHTENING TORQUE	
SIZE	GRADE	SIZE	CLASS	lb	N	ft-lb	N-m
1/2	5	M12	9.8	9046	40239	75.4	101.8
WASHER SPECIFICATIONS							
O. D.		I. D.		THICKNESS			
in	mm	in	mm	in	mm		
2.00	50.80	.51	12.95	.125	3.18		

INSTALLATION DIMENSIONS

PART NUMBER		MAX. AXIAL DEFLECTION		MAX. AXIAL LOAD	
NATURAL RUBBER	NEOPRENE	in	mm	lb	N
4641-76	4641-86	0.1	2.54	240	1068
4641-77	4641-87			310	1379
4641-78	4641-88			450	2002
4641-79	4641-89			560	2491



TITLE: 4641
 THE INFORMATION CONTAINED IN THIS DRAWING IS THE SOLE PROPERTY OF EBCO ANY REPRODUCTION IN PART OR AS A WHOLE WITHOUT THE WRITTEN PERMISSION OF EBCO IS PROHIBITED.
 TOLERANCES PER RMA STANDARD A3
 REV. E
 DATE: 08-21-23
 UNITS: mm [INCH]
 1330 HOLMES RD. ELGIN, IL 60123

SPECIFICATIONS SUBJECT TO CHANGE