

2447

DRG. NO.

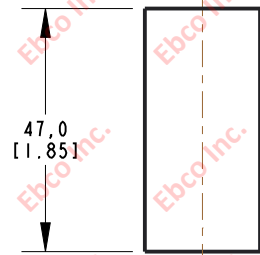

INSTALLATION VIEW (Shown under no load)

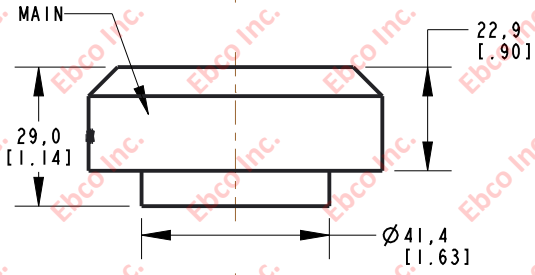
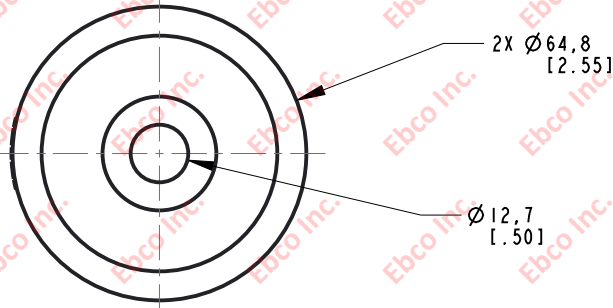
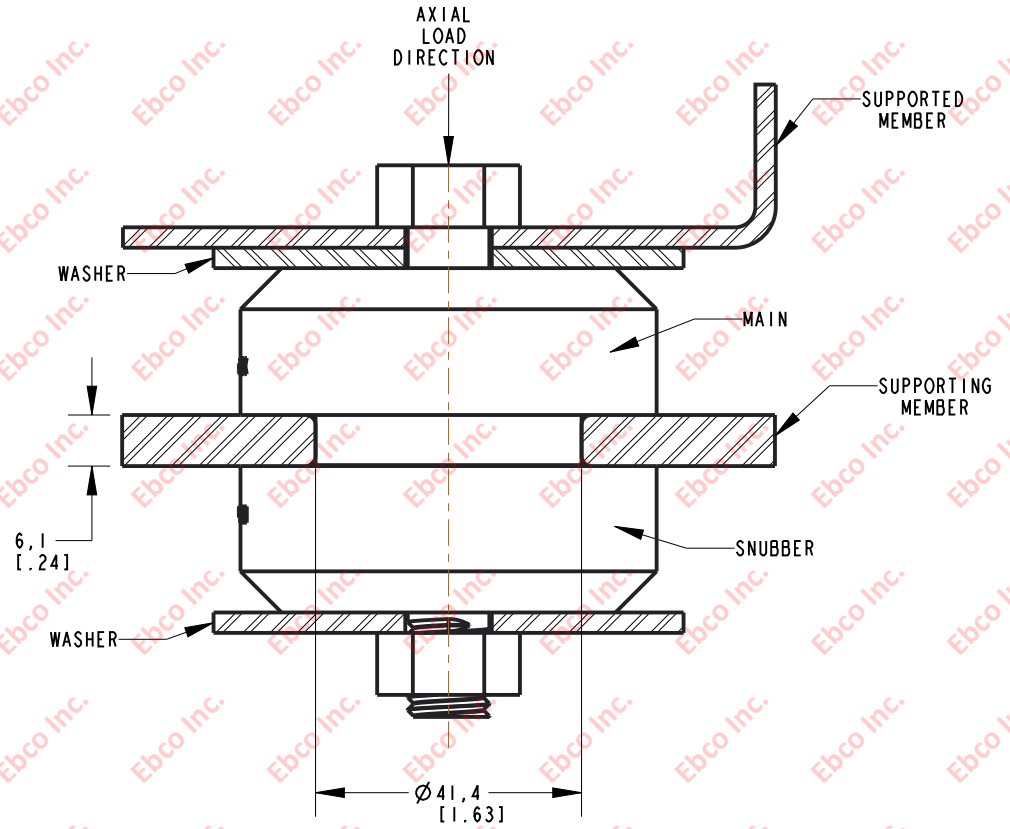

INSTALLATION DIMENSIONS

RECOMMENDED BOLT INFORMATION				TIGHTENING TORQUE			
ENGLISH		METRIC		CLAMP LOAD		TIGHTENING TORQUE	
SIZE	GRADE	SIZE	CLASS	lb	N	ft-lb	N-m
1/2	5	M12	9.8	9046	40239	75.4	101.8
WASHER SPECIFICATIONS							
O. D.		I. D.		THICKNESS			
in	mm	in	mm	in	mm		
2.88	73.15	.52	13.21	.125	3.18		

SPECIFICATIONS

PART NUMBER		MAX. AXIAL DEFLECTION		MAX. AXIAL LOAD	
NATURAL RUBBER	NEOPRENE	in	mm	lb	N
2447-72	2447-82	.09	2.29	275	1223
2447-73	2447-83			350	1557
2447-75	2447-85			575	2558
2447-77	2447-87			950	4226



TITLE: 2447	
THE INFORMATION CONTAINED IN THIS DRAWING IS THE SOLE PROPERTY OF EBCO ANY REPRODUCTION IN PART OR AS A WHOLE WITHOUT THE WRITTEN PERMISSION OF EBCO IS PROHIBITED.	
TOLERANCES PER RMA STANDARD A3	REV. D
DATE: 06-09-21	UNITS: mm [INCH]
1330 HOLMES RD. ELGIN, IL 60123	

SPECIFICATIONS SUBJECT TO CHANGE