

2115

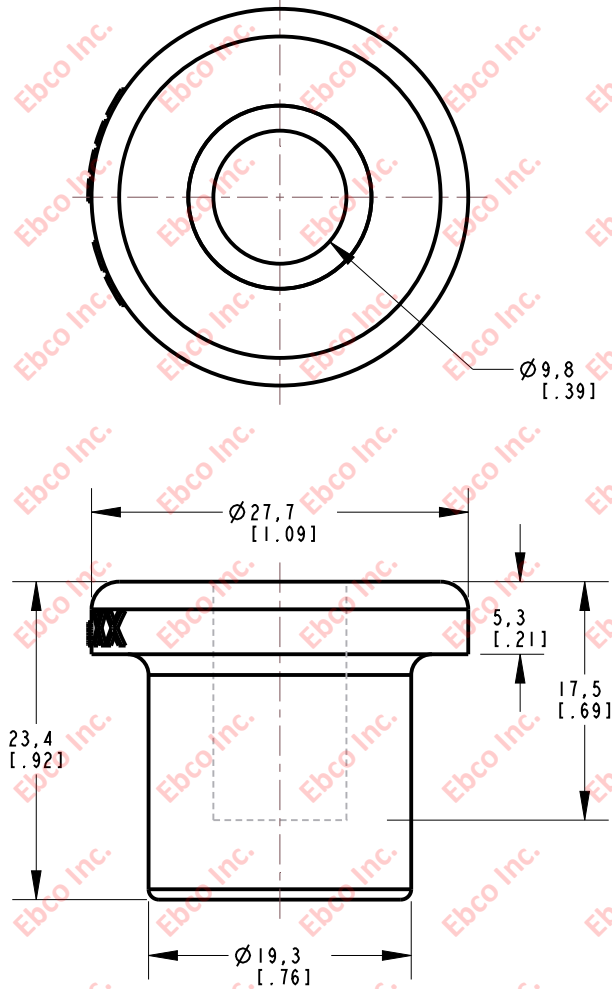

INSTALLATION VIEW (Shown under no load)

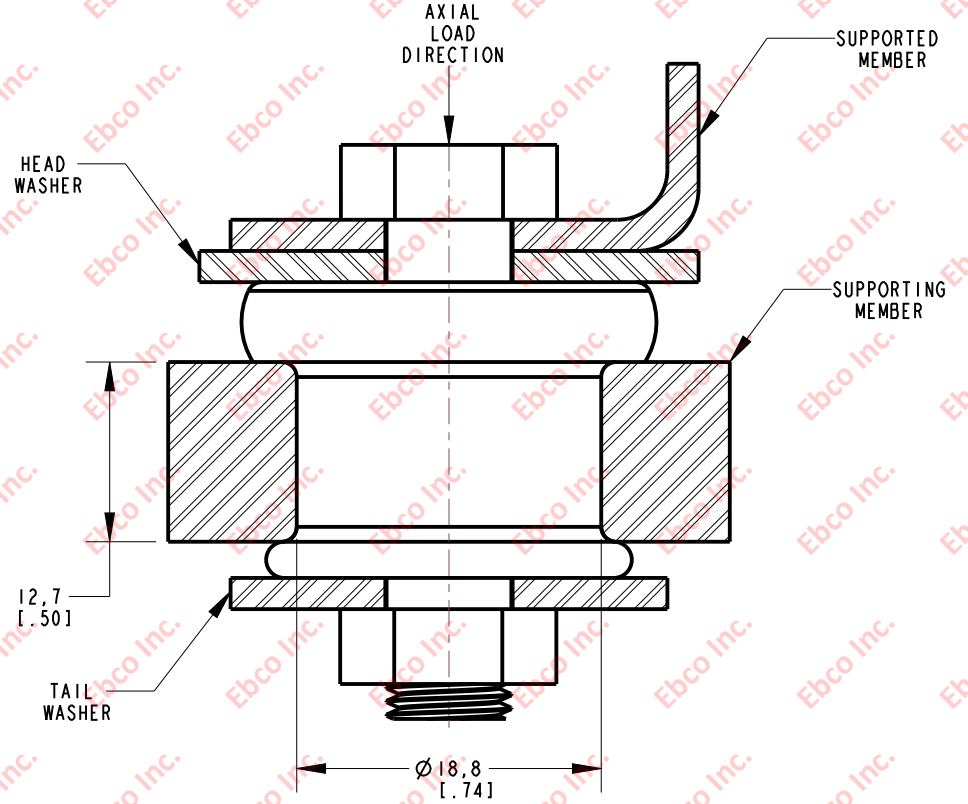

INSTALLATION DIMENSIONS

RECOMMENDED BOLT INFORMATION				TIGHTENING TORQUE			
ENGLISH		METRIC		CLAMP LOAD		TIGHTENING TORQUE	
SIZE	GRADE	SIZE	CLASS	lb	N	ft-lb	N-m
3/8	2	M8	5.8	3197	10400	20.0	16.7
WASHER SPECIFICATIONS							
TYPE	O.D.		I.D.		THICKNESS		
	in	mm	in	mm	in	mm	
HEAD	1.25	31.75	.40	10.16	.125	3.18	
TAIL	1.12	28.45	.40	10.16			

SPECIFICATIONS

PART NUMBER	DUROMETER (SHORE A)
EPDM	± 5
2115-65	60
2115-66	65



TITLE:	2115
THE INFORMATION CONTAINED IN THIS DRAWING IS THE SOLE PROPERTY OF EBCO ANY REPRODUCTION IN PART OR AS A WHOLE WITHOUT THE WRITER PERMISSION OF EBCO IS PROHIBITED.	
TOLERANCES PER RMA STANDARD	REV. G
A3	DATE: 07-26-21
	UNITS: mm [INCH]
1330 HOLMES RD. ELGIN, IL 60123	

SPECIFICATIONS SUBJECT TO CHANGE